

BF MicroBead™ - Adhesive Applicator

The BF MicroBead™ applicator is available with single-port or dual-port pivoting modules, providing flexibility for set-up and reduction of the number of applicators required. It's smaller, more compact design simplifies installation and maintenance while rapid cycle speeds make it an ideal choice for high-speed applications. Its air open/air close design provides accurate and uniform adhesive patterns and bead placement while the built-in filter helps maintain a clean nozzle orifice.

BF MicroBead™ Applicator:

- Integrated needle and self-cleaning nozzle virtually eliminate adhesive stringing. (Micro Optima module)
- Dual-port pivoting modules simplify set-up by providing simple adjustment of bead placement.
- Adjustable needle stroke sets adhesive flow for extreme accuracy. (Micro Adjustable module)
- On/Off cycle speeds of 3.5 milliseconds is ideal for high-speed applications.
- Cover increases safety and promotes energy efficiency.
- Industry exclusive built-in filter captures debris and minimizes nozzle clogging.

Flexibility

Compact size provides for easy installation into packaging machinery.

Safety

Insulated thermoplastic cover increases safety by reducing operator exposure to hot surfaces.

Reliability

Enhanced built-in filter captures debris and reduces downtime due to clogged nozzles.

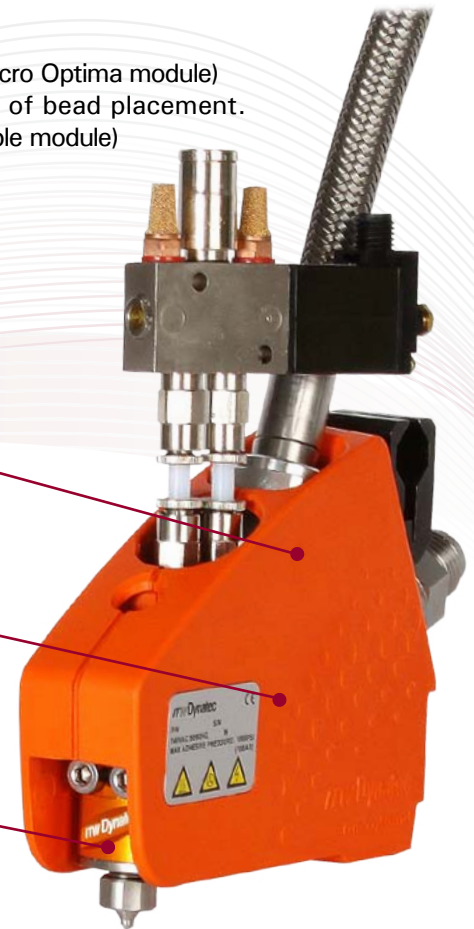

ITW Dynatec - BF MicroBead™ Applicator shown with Single Micro Adjustable Module.

The Dynatec Difference...

Air Open/Air Close Design

The BF MicroBead applicator module is designed to operate as an air open/air close system that does not rely on a spring to close the orifice during operation. The result is both cleaner cutoffs and superior operation over a longer operating lifespan. While this feature may be optional on competitive modules, only ITW Dynatec offers this feature standard on the BF MicroBead adhesive applicator.

BF MicroBead™ - Adhesive Applicator

System	BF MicroBead™
Operating Temperature Range	38°C to 218°C (100°F to 425°F)
Single Port - Max On/Off Cycle Speed	3.5 ms
Dual Port - Max On/Off Cycle Speed	4.0 ms
Dual Port Independent Max On/Off Cycle Speed	3.5 ms
Air Pressure Range	4.8 to 9.5 bar (70 to 140 psi)
Maximum Adhesive Pressure	68 bar (1000 psi)
Adhesive Viscosity Range	100 to 5,000 cps
Solenoid Voltage	24v DC
Supply Voltage	120 or 240 VAC
Filter Mesh Options	100, 150, 200

Dimensions	BF MicroBead™ Single Port	BF MicroBead™ Dual Port Pivot
Height (H)	129 mm (2.08 in)	129 mm (5 in)
Depth (D)	109 mm (4.27 in)	110 mm (4.3 in)
Width (W)	26 mm (1.02 in)	44 mm (1.73 in)

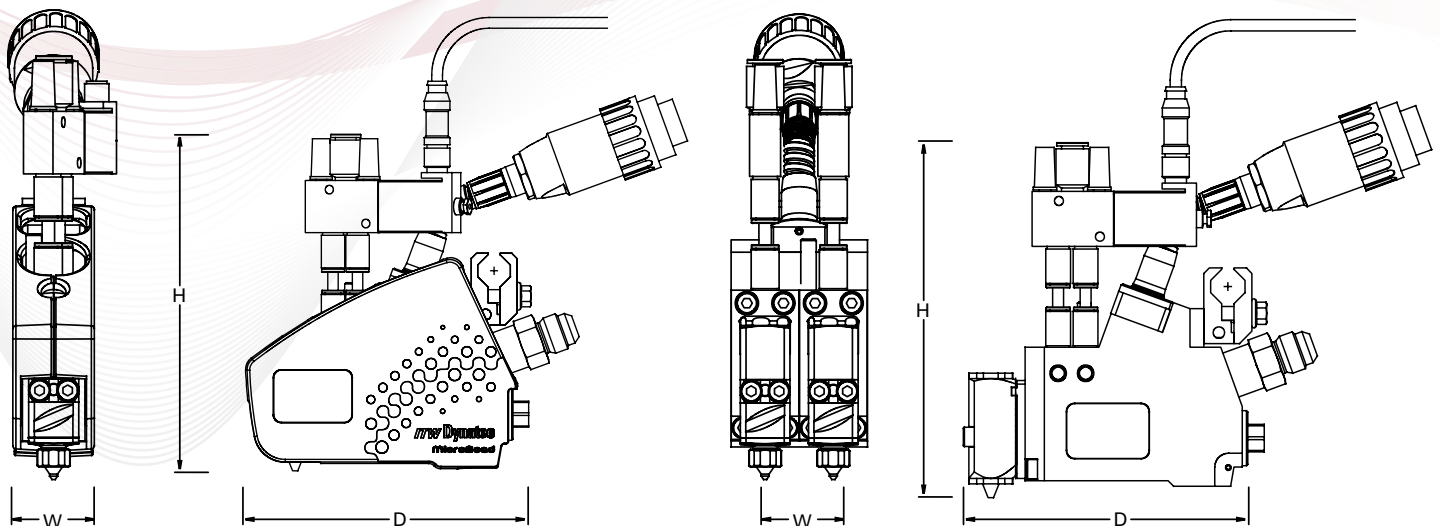

ASIA
 ITW Dynatec Suzhou
 Unit2, B1 Building
 No.9 Weixin Road
 SIP, Suzhou, China 215122
 Telephone +86.512.6289.0620
 Fax +86.512.6289.0621
 dynatecsuzhou@itwdynatec.cn

AMERICAS
 ITW Dynatec
 31 Volunteer Drive
 Hendersonville, TN 37075
 Telephone 615-824-3634
 +1.800.860.6150
 Fax +1.615.264.5248
 dynatec@itwdynatec.com

JAPAN
 ITW Dynatec K.K.
 Tsukimura Building 5th Floor
 26-11, Nishikamata 7-chome
 Ota-ku, Tokyo 144-0051, Japan
 Telephone +81.3.5703.5501
 Fax +81.3.5703.5505
 info@itwdynatec.co.jp

EUROPE, AFRICA and MIDDLE EAST
 ITW Dynatec GmbH
 Industriestrasse 28
 D-40822 Mettmann, Germany
 Telephone +49.210.4915.0
 Fax +49.210.491.5111
 e.mail@itwdynatec.de

© 8/2012 ITW Dynatec
 ITW Dynatec reserves the right to discontinue or change specifications, designs, materials and equipment without notice or obligation.

Visit us at www.itwdynatec.com